

# Combined Temperature/ Humidity Sensor in shelter

3031.0000 BG

Page: 1 / 4

3	12.09		
2	10.09		Zi
1	07.09		Zi
Issue.	Date		Name



## Description

The transmitter type 3031 is designed for measurement of relative humidity and temperature. Sensing is accomplished by capacitive measuring element for humidity and a platinum resistor Pt 100 for temperature measurement. Both sensors are located at the tip of a probe and protected by a membrane filter. The probe is mounted at the base plate by means of a special socket. There the probe is fixed with a fixation screw. The base plate provides 2 holes, 30 mm distance, for M8 screws for fastening.

The unit is protected by a radiation protection shelter, made of a special white plastic material.

Following versions are further available:

Version with electrical ventilation, to obtain exact measuring values even with total calm.

Version with measuring converter which is placed in a housing underneath the sensor. Data output is 4...20 mA each.

## Technical Data

Material of probe:	ABS-plastic
Cable:	(Versions 3031.0000 and .1000 only) LiY( C )Y, 11 x 0.25 mm <sup>2</sup> , length 3 m (fan: LiYY, 2 x 0.25 mm <sup>2</sup> , length 3 m)
Power consumption:	approx. 3.0 mA at 12 V DC (Versions 3031.0000)
Fan:	12 V DC, approx. 70 mA (Versions 3031.1000 and .1200 only)
Humidity sensor:	Capacitive element
Meas. range:	0...100 % rH
Calibrating accuracy:	±1 % rH
Max. annual drift:	1 % rH / year
Time constant:	0.7 s
Output:	0...1 V corresp. 0...100 % rH
Impedance:	> 10 kΩ
Temperature sensor:	Pt 100, according to DIN 60751 B, 1/3 tolerance
Output 1:	Measuring resistance Pt 100, 4 line
Output 2:	0...1 V accordingly -40...+60 °C
Compliances:	WMO Guide No. 8/7th ed.
Power supply:	5...24 V DC; < 4 mA (without fan and electrical ventilation)
Operating temp.:	-40...+85 °C
Dimensions (shelter):	∅ 130 mm, height approx. 185 mm
Weight (shelter with holder):	approx. 780 g
Measuring converter:	Voltage: 0...1.0 V; meas. range: 0...100 % Pt 100, meas. range -35...+45 °C
Input:	
Output:	4...20 mA; supply 18...30 V DC, load depending (500 Ω...1.9 kΩ lin.)
Max. error:	±0.25 %
Error by:	Supply voltage: <50 ppm/V Ambient temp.: <50 ppm/°C
EMV, Emission:	EN 50081-1
EMV, Noise:	EN 50082-2
Connection:	8-p. connector, IP 67 sealed (plugged)

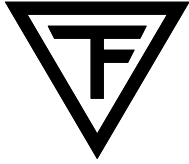

# Combined Temperature/ Humidity Sensor in shelter

3031.0000 BG

Page: 2 / 4

## Ordering Code

Temperature/humidity sensor, in shelter	<b>3031.0000</b>
Temperature/humidity sensor, in shelter, electrically aspirated	<b>3031.1000</b>
Temperature/ humidity sensor incl. measuring converter 4...20 mA, in shelter	<b>3031.0200</b>
Temperature/ humidity sensor incl. measuring converter 4...20 mA, in shelter, electrically aspirated	<b>3031.1200</b>

## Calibration and Maintenance

Calibration and maintenance of the probe should be performed at regular intervals, at least once a year or more often, depending on the conditions of use and desired accuracy.

## Replacing of Sensor

Loosen fixation screw. Pull sensor out of its socket and replace it by a new one. Sensor has to be touched carefully, at its plastic shaft.

## Connection plan

Versions 3031.0000 and 3031.1000

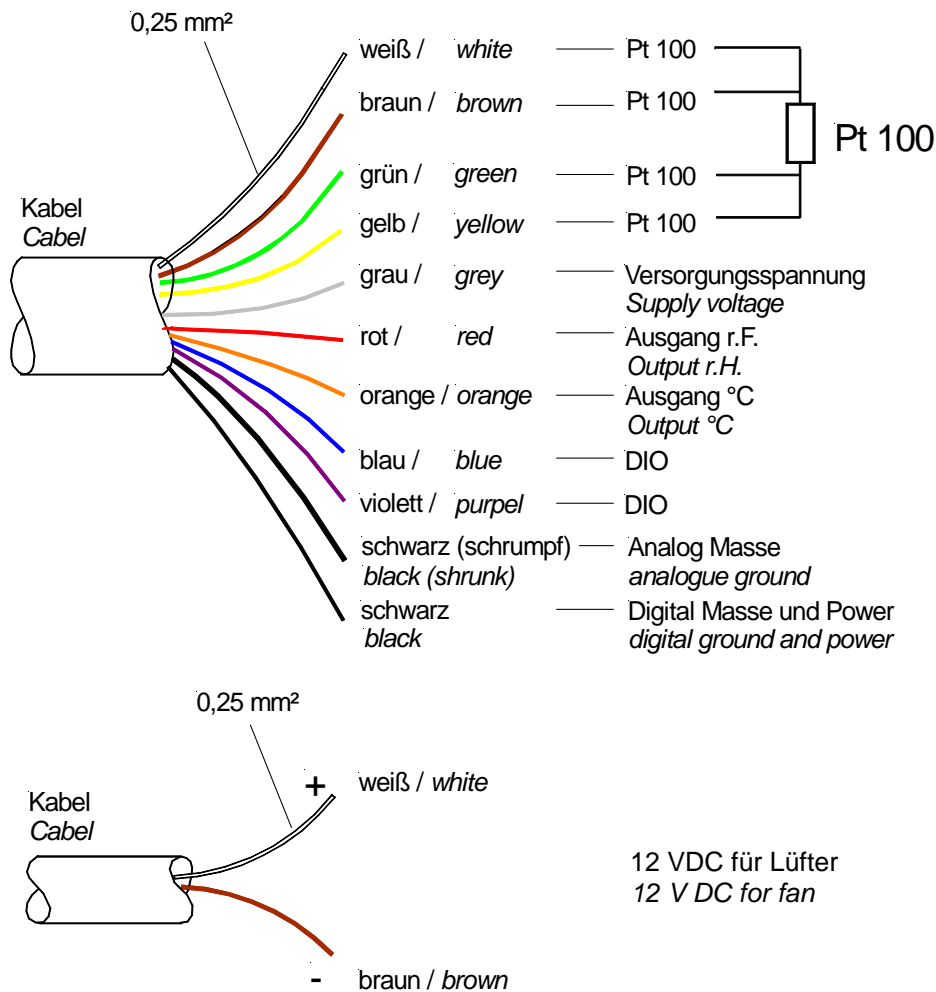

DIO = Digital Input / output;  
used for calibration purpose, only, not used for normal operation!

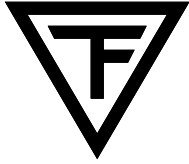

# Combined Temperature/ Humidity Sensor in shelter

3031.0000 BG

Page: 3 / 4

Versions 3031.0200 and 3031.1200; 4...20 mA

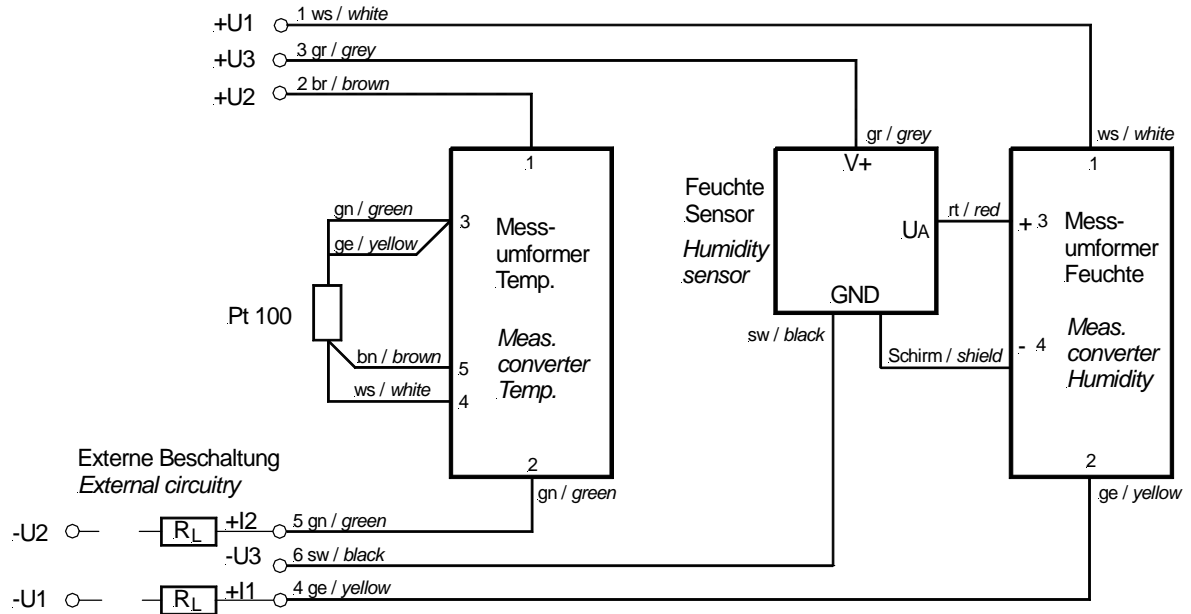

Pin configuration:

ws/white	1	+U1	(Supply meas. conv. humidity)
br/brown	2	+U2	(Supply meas. conv. temp.)
gn/green	3	+U3	(Supply humidity sensor)
ge/yellow	4	+ I1	(4...20 mA humidity)
gr/grey	5	+ I2	(4...20 mA temp.)
rs/pink	6	- U3	(AGND humidity sensor)

+I1/+I2 measured against -U1/-U2  
 U1, U2 = 18...30 V DC (admissible load!).  
 U3 = 3,5...50 V DC (admissible load!).

**Attention:**  
**Power supply U1, U2 must be electrically isolated from U3!**

## Cable Connector

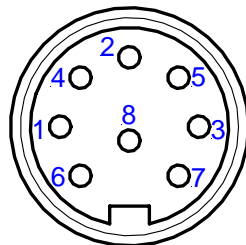

Front side, female socket

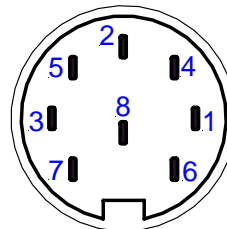

View on the solder termination side

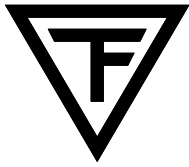

## Dimensions for installation:

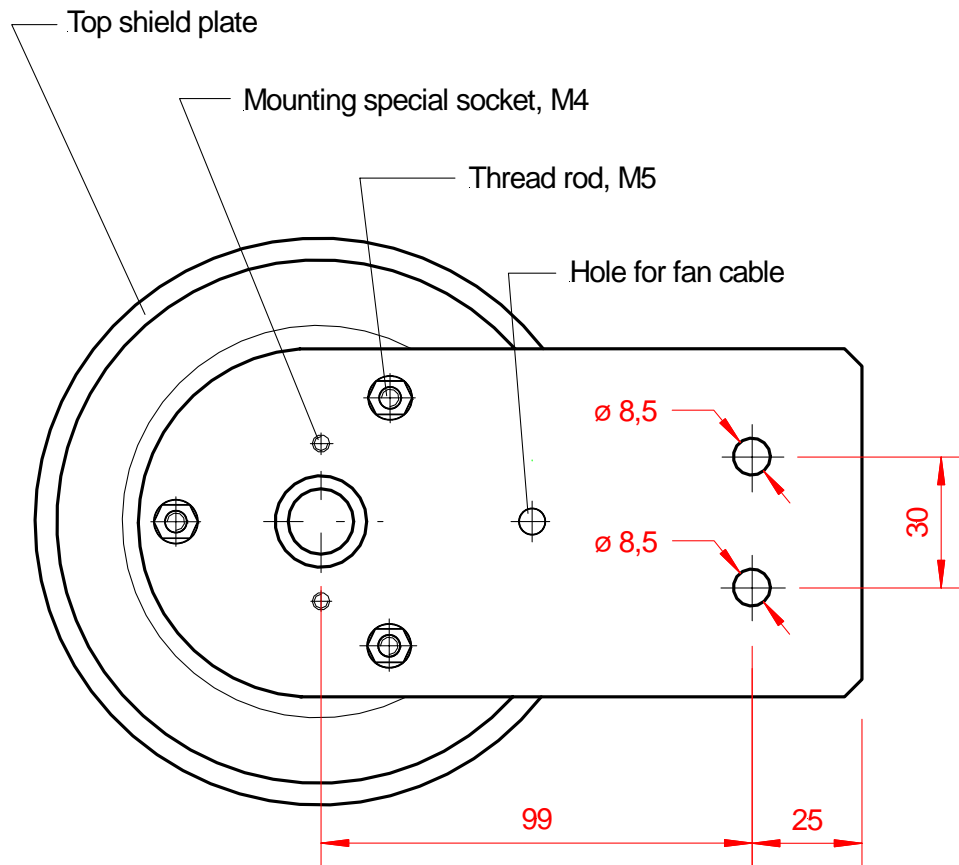

Technical data are subject to change!